

# Polytopes

Kaustubh Mishra

November 21, 2019



## Contents

<b>1</b>	<b>Introduction and Examples</b>	<b>1</b>
<b>2</b>	<b>The Main Theorem</b>	<b>6</b>
<b>3</b>	<b>The Farkas Lemma</b>	<b>11</b>
<b>4</b>	<b>Caratheodory's Theorem</b>	<b>11</b>
<b>5</b>	<b>Faces of Polytopes</b>	<b>12</b>
<b>6</b>	<b>Vertex figure</b>	<b>12</b>
<b>7</b>	<b>Relative interior</b>	<b>13</b>
<b>8</b>	<b>Polarity</b>	<b>13</b>
<b>9</b>	<b>Simplicial and Simple Polytopes</b>	<b>13</b>
<b>10</b>	<b>Linear Programming</b>	<b>14</b>
<b>11</b>	<b>The Hirsch Conjecture</b>	<b>15</b>
<b>12</b>	<b>Kalai's method</b>	<b>15</b>
<b>13</b>	<b>References</b>	<b>15</b>



## 1 Introduction and Examples

In this section we present few examples of polytopes to get introduced with the objects we will deal with through out this report. The definitions provided in this section are not rigorous but clear enough to provide the intuition for the polytopes.

A  $\mathcal{V}$ -polytope is the convex hull of a finite set of points in  $\mathbb{R}^d$ . An  $\mathcal{H}$ -polyhedron is an intersection of finitely many closed halfspaces in  $\mathbb{R}^d$  while an  $\mathcal{H}$ -polytope is an  $\mathcal{H}$ -polyhedron that is bounded in the sense that it does not contain the ray  $\{\mathbf{x} + t\mathbf{y} : t \geq 0\}$  for any  $\mathbf{y} \neq \mathbf{0}$ .

**Definition 1.** *A polytope is a point set  $P \subseteq \mathbb{R}^d$  which can be presented either as a  $\mathcal{V}$ -polytope or as an  $\mathcal{H}$ -polytope. The dimension of a polytope is the dimension of its affine hull.*

Two polytopes  $P \subseteq \mathbb{R}^d$  and  $Q \subseteq \mathbb{R}^e$  are affinely isomorphic,  $P \cong Q$ , if there is an affine map  $f : \mathbb{R}^d \rightarrow \mathbb{R}^e$  that is a bijection between the points of the two polytopes.

Two polytopes  $P, Q$  are combinatorially equivalent,  $P \simeq Q$  if there is a bijection between their faces that preserves the inclusion relation.

**Example 1.** *Zero-dimensional polytopes are points, one-dimensional polytopes are line segments. Thus any 0-polytopes are affinely isomorphic, as are any two 1-polytopes.*

**Example 2.** *Two-dimensional polytopes are called polygons. Two 2-polytopes are combinatorially equivalent iff they have same number of vertices. They forms a combinatorial equivalence class of a convex 2-polytopes with  $n$  vertices. It can be represented as*

$$P_2(n) = \text{conv} \left\{ \left( \cos \left( \frac{2\pi k}{n} \right) \right), \left( \sin \left( \frac{2\pi k}{n} \right) \right) : 0 \leq k < n \right\} \subseteq \mathbb{R}^2$$

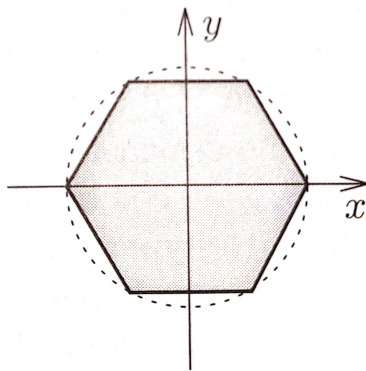

Figure 1: Graph of class  $P_2(n)$

Define a  $d$ -simplex as the convex hull of any  $d+1$  affinely independent points in  $\mathbb{R}^n$  ( $n \geq d$ ). Thus a  $d$ -simplex is a polytope of dimension of  $d$  with  $d+1$  vertices. Any two  $d$ -simplices are affinely isomorphic.

We define the standard  $d$ -simplex  $\Delta_d$  with  $d+1$  vertices in  $\mathbb{R}^{d+1}$ .

$$\Delta_d = \left\{ \mathbf{x} \in \mathbb{R}^{d+1} : \mathbf{1}\mathbf{x} = 1, x_i \geq 0 \right\} = \text{conv} \{ \mathbf{e}_1, \dots, \mathbf{e}_{d+1} \}$$

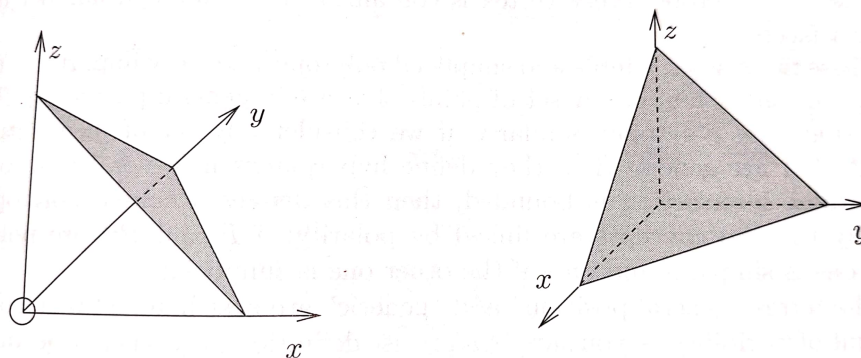

Figure 2: Graph of  $\Delta_2(1)$

**Example 3.** The  $d$  dimensional cube and the  $d$  dimensional crosspolytope, defined as

$$C_d = \{ \mathbf{x} \in \mathbb{R}^d : -1 \leq x_i \leq 1 \} = \text{conv} \{ \{1, -1\}^d \}$$

and

$$C_d^\Delta = \{ \mathbf{x} \in \mathbb{R}^d : \sum_i |x_i| \leq 1 \} = \text{conv} \{ \mathbf{e}_1, -\mathbf{e}_1, \dots, \mathbf{e}_d, -\mathbf{e}_d \}$$

respectively. For  $d=3$  we get  $C_3$  to be usual cube while  $C_3^\Delta$  is an octahedron.

These polytopes are closely related to each other in a way as

$$\begin{aligned} C_d^\Delta &\cong \{ \mathbf{a} \in (\mathbb{R}^d)^* : \mathbf{a}\mathbf{x} \leq 1 \text{ for all } \mathbf{x} \in C_d \} \\ C_d &\cong \{ \mathbf{a} \in (\mathbb{R}^d)^* : \mathbf{a}\mathbf{x} \leq 1 \text{ for all } \mathbf{x} \in C_d^\Delta \} \end{aligned}$$

Such polytopes are polar to each other. Note that the  $d$ -dimensional crosspolytope is a simplicial polytope, all of whose proper faces are simplices, that is, every facet has the minimal number of  $d$  vertices. Similarly the  $d$ -dimensional hypercube is a simple polytope : every vertex is contained in the minimal number of only  $d$  facets.

**Example 4.** Operations that give new polytopes from old ones.

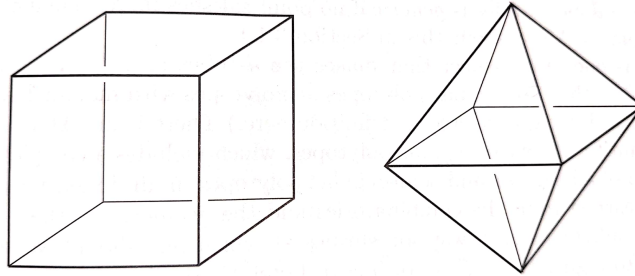
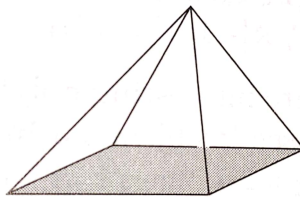
Figure 3: Graph of  $C_3$  and  $C_3^\Delta$ Figure 4: Graph of  $\text{pyr}(P_2(3))$ 

If  $P$  is a  $d$ -polytope and  $\mathbf{x}_0$  is a point outside the affine hull of  $P$ , then the convex hull

$$\text{pyr}(P) = \text{conv}(P \cup \{\mathbf{x}_0\})$$

is a  $(d + 1)$ -dimensional polytope called pyramid over  $P$ . The pyramid over  $\Delta_d$  is  $\Delta_{d+1}$ . Similar is bipyramid  $\text{bipyr}(P)$  by choosing two points  $\mathbf{x}_+$  and  $\mathbf{x}_-$  outside  $\text{aff}(P)$  such that an interior point of the segment  $[\mathbf{x}_+, \mathbf{x}_-]$  is an interior point of  $P$ . Example being bipyramid

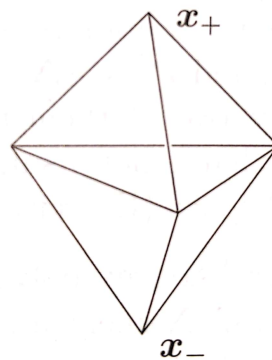
Figure 5: Graph of  $\text{bipyr}(P_2(3))$

over a triangle and the crosspolytopes, which are iterated bipyramids over a point

$$\text{bipyrr}(C_d^\Delta) = C_{d+1}^\Delta$$

Another operation that can be performed is product of two polytopes. Let  $P \subseteq \mathbb{R}^p$  and  $Q \subseteq \mathbb{R}^q$  we define

$$P \times Q = \left\{ \begin{pmatrix} \mathbf{x} \\ \mathbf{y} \end{pmatrix} : \mathbf{x} \in P, \mathbf{y} \in Q \right\}$$

which is a polytope of dimension  $\dim(P) + \dim(Q)$ , whose nonempty faces are the products of nonempty faces of  $P$  and nonempty faces of  $Q$ .

The prism over a polytope  $P$  is the product of  $P$  with a segment

$$\text{prism}(P) = P \times \Delta_1$$

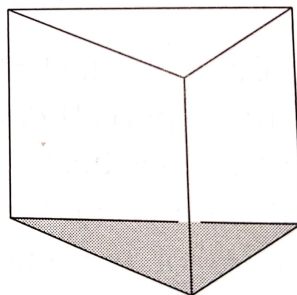

Figure 6: Graph of  $\Delta_2 \times \Delta_1$

This is polar to the bipyramid

$$\text{prism}(P) = (\text{bipyrr}(P^\Delta))^\Delta$$

Some interesting examples are  $\Delta_2 \times \Delta_1$  which is a triangular prism. Cube can also be interpreted as iterated prism, starting with a point. In particular,  $C_d \times [-1, 1] = C_{d+1}$ .

**Example 5.** *If we apply an affine map  $\pi$  to a polytope  $P$ , then we get a new polytope  $\pi(P)$ , If the affine map is injective then image polytope  $\pi(P)$  is affinely isomorphic to the original one.*

One can also take affine maps that project  $P$  to a polytope  $f(P)$  of lower dimension.

The convex hull

$$\text{conv}\{\mathbf{x}_1, \dots, \mathbf{x}_n\} \subseteq \mathbb{R}^d$$

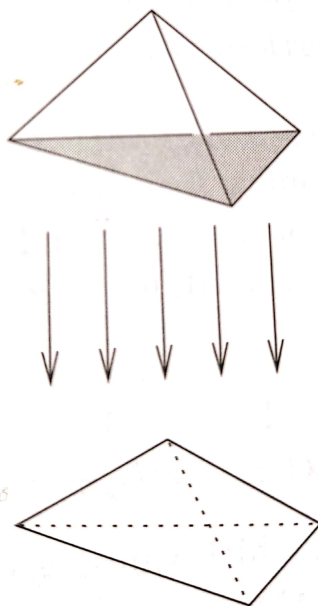
Figure 7: Projection of  $P$ 

can be interpreted as the image of the standard simplex  $\Delta_{n-1} \subseteq \mathbb{R}^n$ , under the linear map  $\pi : \mathbb{R}^n \rightarrow \mathbb{R}^d$ , mapping  $\mathbf{e}_i \rightarrow \mathbf{x}_i$ . This can be interpreted as a projection of polytopes. Thus  $\mathcal{V}$ -polytope is same as projection of a polytope and every projection of a polytope is a polytope as well. A good example is

Every affine image(projection) of a crosspolytope is centrally symmetric.

In fact every centrally symmetric polytope is the projection of a crosspolytope.

A polytope  $P$  is centrally symmetric if it has a center, a point  $\mathbf{x}_0 \in \mathbb{R}^d$  such that  $\mathbf{x}_0 + \mathbf{x} \in P$  holds iff  $\mathbf{x}_0 - \mathbf{x} \in P$ .

**Example 6.** An interesting class of polytopes are 0/1-polytopes, all of whose vertex coordinates are 0 or 1. In other words a 0/1-polytope is the convex hull of a subset of the vertices of a unit cube.

A  $(d-1)$ -simplex  $\Delta_{d-1} \subseteq \mathbb{R}^d$  is a 0/1 polytope. Similarly one can study hypersimplex  $\Delta_{d-1}(k)$  defined as

$$\Delta_{d-1}(k) = \text{conv}\{\nu \in \{0, 1\}^d : \sum_{i=1}^d \nu_i = k\} \quad \text{for } 1 \leq k \leq d-1$$

This family includes the standard simplex as  $\Delta_{d-1} = \Delta_{d-1}(1)$ . The hypersimplex  $\Delta_{d-1}(k)$

has  $\binom{d}{k}$  vertices and  $2d$  facets, if  $2 \leq k \leq d - 2$ . For example, the 3-dimensional hypersimplex  $\Delta_3(2) \subseteq \mathbb{R}^4$  is combinatorially equivalent to an octahedron.

**Example 7.** A construction of a special kind of a 0/1-polytopes. Let  $S_d$  denote the set of all permutations of the set  $[d]$ . With every permutation  $\sigma$  in  $S_d$  we associate the matrix  $X^\sigma$ , given by

$$X_{ij}^\sigma = \begin{cases} 1 & \text{if } \sigma(i) = j \\ 0 & \text{otherwise} \end{cases}$$

The matrices  $X^\sigma$  are the 0/1-matrices with exactly one 1 per row and per column. If we identify  $\mathbb{R}^{d^2}$  with the set of all real  $(d \times d)$ -matrices, then the matrices  $X^\sigma$  are 0/1-vectors in  $\mathbb{R}^{d^2}$ , and their convex hull forms a 0/1-polytope

$$P(d) = \text{conv}\{X^\sigma : \sigma \in S_d\} \subseteq \mathbb{R}^{d^2}$$

The polytope  $P(d)$  has  $d!$  vertices,  $d^2$  facets, and dimension  $(d - 1)^2$ .

## 2 The Main Theorem

In this section we provide the statement and proof of the **Main Theorem** but before we need some definitions.

**Definition 2.** A  $\mathcal{H}$ -polyhedron denotes an intersection of closed halfspaces: a set  $P \subseteq \mathbb{R}^d$  presented in the form

$$P = P(A, \mathbf{z}) = \{\mathbf{x} \in \mathbb{R}^d : A\mathbf{x} \leq \mathbf{z}\} \text{ for some } A \in \mathbb{R}^{m \times d}, \mathbf{z} \in \mathbb{R}^m$$

$A\mathbf{x} \leq \mathbf{z}$  is the shorthand for a system of inequalities  $a_1x \leq z_1, \dots, a_mx \leq z_m$  where  $a_1, \dots, a_m$  are rows of  $A$  and  $z_1, \dots, z_m$  are components of  $\mathbf{z}$ . For an arbitrary subset  $Y \subseteq \mathbb{R}^d$ , we define its conical hull  $\text{cone}(Y)$  as the intersection of all cones in  $\mathbb{R}^d$  that contains  $Y$ .

$$\text{cone}(Y) = \{\lambda_1 y_1 + \dots + \lambda_k y_k : \{y_1, \dots, y_k\} \subseteq Y, \lambda_i \geq 0\}$$

In case of finite set  $Y = \{y_1, \dots, y_n\}$ .

$$\text{cone}(Y) = \{t_1 y_1 + \dots + t_n y_n : t_i \geq 0\} = \{Y\mathbf{t} : \mathbf{t} \geq 0\}$$

We define that  $\text{cone}(Y) = \{0\}$  if  $Y$  is the empty set.

**Definition 3.** The vector sum or Minkowski sum of two sets  $P, Q \subseteq \mathbb{R}^d$  is defined to be

$$P + Q = \{x + y : x \in P, y \in Q\}$$

**Definition 4.** A  $\mathcal{V}$ -polyhedron to denote any finite generated convex-conical combination : a set  $P \subseteq \mathbb{R}^d$  that is given in the form

$$P = \text{conv}(V) + \text{cone}(Y) \text{ for some } V \in \mathbb{R}^{d \times n}, Y \in \mathbb{R}^{d \times n'}$$

as the Minkowski sum of a convex hull of a finite point set and the cone generated by a finite set of vectors.

A  $\mathcal{V}$ -polytope is a  $\mathcal{V}$ -polyhedron that is bounded , that is, contains no ray  $\{u + tv : t \geq 0\}$  with  $v \neq 0$ .

**Theorem 1. (Main theorem for polytopes)** A subset  $P \subseteq \mathbb{R}^d$  is the convex hull of a point set ( $\mathcal{V}$ -polytope)

$$P = \text{conv}(V) \text{ for some } V \in \mathbb{R}^{d \times n}$$

if and only if it is bounded intersection of halfspaces ( $\mathcal{H}$ -polytope)

$$P = P(A, z) \text{ for some } A \in \mathbb{R}^{m \times d}, z \in \mathbb{R}^m$$

We can generalize it to a theorem about polyhedra.

**Theorem 2. (Main theorem for polyhedra)** A subset  $P \subseteq \mathbb{R}^d$  is sum of a convex hull of a finite set of points plus a conical combination of vectors ( $\mathcal{V}$ -polyhedra)

$$P = \text{conv}(V) + \text{cone}(Y) \text{ for some } V \in \mathbb{R}^{d \times n}, Y \in \mathbb{R}^{d \times n'}$$

if and only if it is an intersection of closed halfspaces (an  $\mathcal{H}$ -polyhedra)

Note that Theorem1 follows from Theorem2 as polytopes are bounded polyhedra , in both  $\mathcal{V}$  and the  $\mathcal{H}$  forms. The theorem is tedious to prove in this form so we homogenize that is pass from affine  $d$  space to linear  $(d + 1)$  space , for this we adjoin an extra coordinate mapping the point  $\mathbf{x} \in \mathbb{R}^d$  to the vector  $\begin{pmatrix} 1 \\ \mathbf{x} \end{pmatrix} \in \mathbb{R}^{d+1}$  .

This reduces the theorem to the special case where  $P$  is cone, which can be proved more easily.

**Theorem 3. (Main theorem for cones)** A cone  $C \subseteq \mathbb{R}^d$  is finitely generated combination of vectors

$$C = \text{cone}(Y) \text{ for some } Y \in \mathbb{R}^{d \times n}$$

if and only if it is a finite intersection of closed linear halfspaces

$$C = P(A, \mathbf{0}) \text{ for some } A \in \mathbb{R}^{m \times d}$$

Main theorem for polyhedra follows from Main theorem for cones.

Let  $P = \text{conv}(V) + \text{cone}(Y) \in \mathbb{R}^d$  be a  $\mathcal{V}$ -polyhedra we define  $C(P)$  to be  $\mathcal{V}$ -cone

$$C(P) = \text{cone} \left( \begin{array}{c|c} \mathbf{1} & \mathbb{O} \\ \hline V & Y \end{array} \right) \subseteq \mathbb{R}^{d+1}$$

Let  $H$  be the hyperplane  $x_0 = 1$ , then  $C(P) \cap H = P$ .

$C(P)$  is an  $\mathcal{H}$ -cone (By Theorem as  $C(P)$  is  $\mathcal{V}$ -cone). So  $P = C(P) \cap H$  is an  $\mathcal{H}$ -polyhedron (as we added just some linear condition on  $C(P)$ ).

Conversely let  $P = P(A, \mathbf{z})$  be an  $\mathcal{H}$ -polyhedron, we define  $C(P)$  to be an  $\mathcal{H}$ -cone

$$C(P) = P \left( \left( \begin{array}{c|c} -1 & \mathbb{O} \\ \hline -\mathbf{z} & A \end{array} \right), \left( \begin{array}{c} 0 \\ \mathbf{0} \end{array} \right) \right) \subseteq \mathbb{R}^{d+1}$$

So  $C(P)$  is defined by the inequalities

$$-z_i x_0 + \mathbf{a}_i \mathbf{x} \leq 0 \text{ and } -x_0 \leq 0$$

Again  $C(P) \cap H = P$ . Also  $C(P)$  is  $\mathcal{V}$ -cone (by theorem), then  $C(P)$  can be presented in the form of

$$\text{cone} \left( \begin{array}{c|c} \mathbf{1} & \mathbb{O} \\ \hline V & Y \end{array} \right)$$

This is an associated cone to a  $\mathcal{V}$ -polyhedron thus it follows  $P = \text{conv}(V) + \text{cone}(Y)$  is a  $\mathcal{V}$ -polyhedron.

Given an  $\mathcal{H}$ -polyhedron  $P = P(A, \mathbf{z})$ . We define projection of it to  $\{\mathbf{x} \in \mathbb{R}^d : x_k = 0\}$  as

$$\begin{aligned} \text{proj}_k(P) &= \{\mathbf{x} - x_k \mathbf{e}_k : \mathbf{x} \in P\} \\ &= \{\mathbf{x} \in \mathbb{R}^d : x_k = 0, \exists y \in \mathbb{R} : \mathbf{x} + y \mathbf{e}_k \in P\} \end{aligned}$$

Note that the set  $\text{proj}_k(P)$  is contained in the hyperplane  $H_k = \{\mathbf{x} \in \mathbb{R}^d : x_k = 0\}$ .

$$\begin{aligned} \text{elim}_k(P) &= \{\mathbf{x} - t \mathbf{e}_k : \mathbf{x} \in P, t \in \mathbb{R}\} \\ &= \{\mathbf{x} \in \mathbb{R}^d : \exists y \in \mathbb{R} : \mathbf{x} + y \mathbf{e}_k \in P\} \end{aligned}$$

The set  $\text{elim}_k(P)$  is set of all points in  $\mathbb{R}^d$  which project to  $\text{proj}_k(P)$ . We get an isomorphism  $\text{elim}_k(P) \cong \text{proj}_k(P) \times \mathbb{R}$ .

*Proof.* For the "forward direction" let  $C = \text{cone}(Y) \subseteq \mathbb{R}^d$  be a  $\mathcal{V}$ -cone.

$$\begin{aligned} C &= \{Y \mathbf{t} \in \mathbb{R}^d : \mathbf{t} \geq 0\} \\ &= \{\mathbf{x} \in \mathbb{R}^d : \exists \mathbf{t} \in \mathbb{R}^d : \mathbf{t} \geq 0, \mathbf{x} = Y \mathbf{t}\} \end{aligned}$$

- If the columns of  $Y$  are linearly independent, then there exists a linear transformation from  $C = \text{cone}(Y)$  to the  $\text{cone}(\mathbf{e}_1, \dots, \mathbf{e}_n)$ , which is an  $\mathcal{H}$ -cone given by the inequalities

$$x_1 \geq 0, x_2 \geq 0, \dots, x_n \geq 0, x_i = 0 \text{ } i \neq 1, 2, \dots, n$$

- If column of  $Y$  are linearly dependent, then append some rows with arbitrary entries to  $Y$  to form a matrix  $Y'$  with linearly independent columns. Then  $C' = \text{cone}(Y')$  will be an  $\mathcal{H}$ -cone and  $C$  is obtained from  $C'$  by projecting away extra coordinates.

Consider  $C' = \text{cone}(Y')$  where  $Y'$  is formed by appending the identity matrix to rows of the  $Y$  then the set

$$\left\{ (\mathbf{x}, \mathbf{t}) \in \mathbb{R}^{d+n} : \mathbf{t} \geq 0, \mathbf{x} = Y\mathbf{t} \right\} = \text{cone}(Y')$$

Columns of  $Y'$  are linearly independent. So  $C'$  is an  $\mathcal{H}$ -cone. Thus  $C = \text{cone}(Y)$  can be written as the projection of this cone to the subspace

$$\left\{ (\mathbf{x}, \mathbf{t}) \in \mathbb{R}^{d+n} : \mathbf{t} = 0 \right\}$$

This projection can be formed successively, by projecting with respect to individual  $t_k$ -coordinates one by one.

Thus for "forward direction" it is suffice to prove the following lemma

**Lemma 1.** *If  $C = P(A, \mathbf{0})$  is an  $\mathcal{H}$ -cone in  $\mathbb{R}^d$ , then so is the elimination  $\text{elim}_k(C) = \{ \mathbf{x} - t\mathbf{e}_k : \mathbf{x} \in C, t \in \mathbb{R} \}$ , and thus also the projection  $\text{proj}_k(C) = \text{elim}_k(C) \cap H_k$ . and we get  $\text{elim}_k(C) = P(A^{'k}, \mathbf{0})$  for*

$$A^{'k} = \{ \mathbf{a}_i : a_{ik} = 0 \} \cup \{ a_{ik}\mathbf{a}_j + (-a_{jk})\mathbf{a}_i : a_{ik} > 0, a_{jk} < 0 \}$$

The row vectors in  $A^{'k}$  are positive combinations of row vectors in  $A$ . So  $C \subseteq P(A^{'k}, \mathbf{0})$ . Furthermore the row vectors in  $A^{'k}$  all have the  $k$ th component 0. So variable  $x_k$  does not appear in the system  $A^{'k}\mathbf{x} \leq 0$ , which proves that  $\text{elim}_k(C) \subseteq P(A^{'k}, \mathbf{0})$ . For the converse let  $\mathbf{x} \in P(A^{'k}, \mathbf{0})$  and let  $x_k = 0$  (without loss of generality). We claim that  $\mathbf{x} - y\mathbf{e}_k \in C$  for suitable  $y$ . Plugging into system  $A\mathbf{x} \leq 0$ ,  $y$  has to satisfy

$$\max_i \left\{ \frac{1}{a_{ik}} \mathbf{a}_i \mathbf{x} : a_{ik} > 0 \right\} \leq y \leq \min_i \left\{ \frac{1}{-a_{jk}} (-\mathbf{a}_j) \mathbf{x} : a_{jk} < 0 \right\}$$

This can be satisfied, if  $a_{ik} > 0$  and  $a_{jk} < 0$ , then we know that  $\frac{1}{a_{ik}} \mathbf{a}_i \mathbf{x} \leq \frac{1}{-a_{jk}} (-\mathbf{a}_j) \mathbf{x}$  which is equivalent to

$$(a_{ik}\mathbf{a}_j + (-a_{jk})\mathbf{a}_i) \mathbf{x} \leq 0$$

which holds as  $\mathbf{x} \in P(A^{'k}, \mathbf{0})$

For the "backward direction" let  $C = P(A, \mathbf{0}) \subseteq \mathbb{R}^d$  be an  $\mathcal{H}$ -cone.

$$\begin{aligned} C &= \{ \mathbf{x} \in \mathbb{R}^d : A\mathbf{x} \leq 0 \} \\ &\cong \left\{ \begin{pmatrix} \mathbf{x} \\ \mathbf{w} \end{pmatrix} \in \mathbb{R}^{d+m} : A\mathbf{x} \leq \mathbf{w} \right\} \cap \left\{ \begin{pmatrix} \mathbf{x} \\ \mathbf{w} \end{pmatrix} \in \mathbb{R}^{d+m} : \mathbf{w} = \mathbf{0} \right\} \end{aligned}$$

- If the rows of  $A$  are linearly independent, then there exists a linear transformation taking  $C$  to the cone  $\{x_1, x_2, \dots, x_n\} x_i \geq 0$ . This is a  $\mathcal{V}$ -cone generated by  $\mathbf{e}_1, \mathbf{e}_2, \dots, \mathbf{e}_n$  and  $\pm \mathbf{e}_i$  for  $i \neq 1, \dots, n$
- If the rows of  $A$  are linearly dependent, then append some columns with arbitrary entries to  $A$  to form a matrix  $A'$  with linearly independent rows. Then  $C' = P(A', \mathbf{0})$  will be a  $\mathcal{V}$ -cone and  $C$  is obtained from  $C'$  by intersecting with the linear space in which the extra coordinates are  $\mathbf{0}$ .

Consider  $C' = P(A', \mathbf{0})$  where  $A'$  is formed by appending the identity matrix to columns of  $A$  then the set

$$\left\{ \begin{pmatrix} \mathbf{x} \\ \mathbf{w} \end{pmatrix} \in \mathbb{R}^{d+m} : A\mathbf{x} \leq \mathbf{w} \right\} = P(A', \mathbf{0})$$

Rows of  $A'$  are linearly independent. So  $C'$  is an  $\mathcal{V}$ -cone. Thus  $C = P(A, \mathbf{0})$  can be written as the intersection of it with the subspace

$$\left\{ \begin{pmatrix} \mathbf{x} \\ \mathbf{w} \end{pmatrix} \in \mathbb{R}^{d+m} : \mathbf{w} = \mathbf{0} \right\}$$

This intersection can be formed successively, by setting coordinates to zero one by one. i.e. intersecting with coordinate hyperplanes of the form  $H_k = \{\mathbf{y} \in \mathbb{R}^{d+m} : y_k = 0\}$ . Thus for "backward direction" it is suffice to prove the following lemma

**Lemma 2.** *If  $C = \text{cone}(Y)$  is an  $\mathcal{V}$ -cone in  $\mathbb{R}^d$ , then so is the intersection  $C \cap H_k$ , and we get  $C \cap H_k = \text{cone}(Y'^k)$  for*

$$Y'^k = \{\mathbf{y}_i : y_{ki} = 0\} \cup \{y_{ki}\mathbf{y}_j + (-y_{kj})\mathbf{y}_i : y_{ki} > 0, y_{kj} < 0\}$$

Note that the vectors in  $Y'^k$  all have  $x_k$ -coordinate 0, so  $C \cap H_k \supseteq \text{cone}(Y'^k)$ . For reverse inclusion, we consider some  $\mathbf{v} = Y\mathbf{t} \in \text{cone}(Y)$  ( $\mathbf{t} \geq 0$ ) with  $v_k = 0$ . Now either we have  $t_i y_{ki} = 0$  for all  $i$ , and we get  $\mathbf{v} \in \text{cone}(\{\mathbf{y}_i : y_{ki} = 0\})$  or we can expand  $v_k = 0$  to get

$$\Lambda = \sum_{i:y_{ki}>0} t_i y_{ki} = \sum_{j:y_{kj}<0} t_j (-y_{kj}) > 0$$

$$\begin{aligned}
\mathbf{v} &= \sum_{i:y_{ki}=0} t_i \mathbf{y}_i + \sum_{i:y_{ki}>0} t_i \mathbf{y}_i + \sum_{j:y_{kj}<0} t_j \mathbf{y}_j \\
&= \sum_{i:y_{ki}=0} t_i \mathbf{y}_i + \frac{1}{\Lambda} \sum_{i:y_{ki}>0} \left( \sum_{j:y_{kj}<0} t_j (-y_{kj}) \right) t_i \mathbf{y}_i \\
&\quad + \frac{1}{\Lambda} \sum_{j:y_{kj}<0} \left( \sum_{i:y_{ki}>0} t_i y_{ki} \right) t_j \mathbf{y}_j \\
&= \sum_{i:y_{ki}=0} t_i \mathbf{y}_i + \sum_{i:y_{ki}>0} \sum_{j:y_{kj}<0} \frac{t_i t_j}{\Lambda} ((-y_{kj} \mathbf{y}_i + y_{ki} \mathbf{y}_j))
\end{aligned}$$

This gives  $\mathbf{v}$  a representation as conical sum of vectors in  $Y^k$  □

### 3 The Farkas Lemma

**Lemma 3.** *Let  $C = \text{cone}(A)$  be a polyhedral cone with  $A \in \mathbb{R}^m \times d$  and let  $z \in \mathbb{R}^m$ . Then either*

- $z \in C$  (i.e. there exists  $x \in \mathbb{R}^d$  with  $x \geq 0$  and  $Ax = z$ ) or
- there is a hyperplane that separates  $C$  from  $z$  (i.e. there exists  $c \in (\mathbb{R}^m)^*$  with  $cA \geq 0$  and  $cz \leq 0$ ) but not both.

*Proof.* Both possibilities cannot hold as if  $x \geq 0$  and  $Ax = z$  then  $cA \geq 0$  implies  $0 \leq cAx = cz$  so we cannot have  $cz \leq 0$ .

By Fourier Motzkin elimination, the cone  $C$  can be described as a  $H$  cone  $P(B, 0)$ . Thus if  $z \notin C$ , then some row of  $-B$  separates  $C$  from  $z$ . □

### 4 Caratheodory's Theorem

**Theorem 4.** *Let  $X \subset \mathbb{R}^d$  and  $x \in \text{cone}(X)$ . Then there is a subset  $X' \subseteq X$  of size at most  $\dim \text{cone}(X)$  such that  $x \in \text{cone}(X')$ .*

*Proof.* Since  $x \in \text{cone}(X)$ , we can write  $x = \sum_{i=1}^k \lambda_i x_i$  with  $\lambda_i > 0$ ,  $x_i \in X$  and  $k$  minimal. If  $k \leq \dim \text{cone}(X)$ , then we are done. Otherwise the vectors  $x_1, \dots, x_k$  are linearly dependent, write  $\sum_{i=1}^k \mu_i x_i = 0$ , where not all  $\mu_i$  vanishes. Assume without loss of generality that the maximum value of  $\|\frac{\mu_i}{\lambda_i}\|$  occurs when  $i = k$ . By scaling the relation, we may assume that  $\mu_k = \lambda_k$  and  $\mu_i < \lambda_i$  for  $i \neq k$ . Then  $x = \sum_{i=1}^{k-1} (\lambda_i - \mu_i) x_i$  is shorter representation of  $x \in \text{cone}(X)$ . □

## 5 Faces of Polytopes

**Definition 5.** Let  $P$  be a convex polytope. A linear inequality  $cx \leq c_0$  is valid for  $P$  if it satisfied for all points  $x \in P$ . A face of  $P$  is any set of the form

$$F = P \cap \{x \in \mathbb{R}^d : cx = c_0\}$$

where  $cx \leq c_0$  is a valid inequality for  $P$ .

**Proposition 1.** Let  $P \subseteq \mathbb{R}^d$  be a polytope

1. Every polytope is the convex hull of its vertices  $P = \text{conv}(\text{vert}(P))$ .
2. If a polytope can be written as the convex hull of a finite points set then the set contains all the vertices of the polytope  $P = \text{conv}(V)$  implies  $\text{vert}(P) \subseteq V$ .

**Proposition 2.** Let  $P$  be a polytope and  $V = \text{vert}(P)$ . Let  $F$  be a face of  $P$ .

1. The face  $F$  is a polytope with  $\text{vert}(F) = F \cap V$ .
2. Every intersection of faces of  $P$  is a face of  $P$ .
3. The faces of  $F$  are exactly the faces of  $P$  that are contained in  $F$ .
4.  $F = P \cap \text{aff}(F)$ .

## 6 Vertex figure

**Definition 6.** Let  $P$  be a polytope with  $V = \text{vert}(P)$  and a vertex  $v \in V$ . Let  $cx \leq c_0$  be a valid inequality with

$$\{v\} = P \cap \{x : cx = c_0\}$$

Further choose some  $c_1 \leq c_0$  with  $cv' < c_1$  for all  $v' \in \text{vert}(P) - \{v\}$ . Then we define a vertex figure of  $P$  at  $v$  as the polytope

$$P/v = P \cap \{x : cx = c_1\}$$

**Proposition 3.** There is a bijection between the  $k$  dimensional faces of  $P$  that contains  $v$  and the  $(k - 1)$  dimensional faces of  $P/v$  given by

$$\begin{aligned} \pi & : & F & \longrightarrow F \cap \{x : cx = c_1\} \\ \sigma & : & P \cap \text{aff}(\{v\} \cup F') & \longleftarrow F' \end{aligned}$$

## 7 Relative interior

Relative interior of polytope is defined as the interior of  $P$  with respect to the embedding of  $P$  into its affine hull, in which  $P$  is full dimensional.

It follows that the  $x \in P$  lies in the relative interior of some face, namely the smallest face containing it. Thus  $P$  can be written as the disjoint union of the relative interior of its faces.

$$P = \bigsqcup \text{relint}(F)$$

## 8 Polarity

**Definition 7.** For any subset  $P \subseteq \mathbb{R}^d$ , the polar set is defined by

$$P^\Delta = \{c \in (\mathbb{R}^d)^* : cx \leq 1 \forall x \in P\} \subseteq (\mathbb{R}^d)^*$$

**Theorem 5.** 1.  $P \subseteq Q$  implies  $P^\Delta \supseteq Q^\Delta$  and  $P^{\Delta\Delta} \subseteq Q^{\Delta\Delta}$

2.  $P \subseteq P^\Delta$ .

3.  $P^\Delta$  and  $P^{\Delta\Delta}$  are convex

4.  $0 \in P$

5. if  $P$  is a polytope and  $0 \in P$ . then  $P = P^{\Delta\Delta}$

6. if a polytope  $P$  with  $0 \in \text{int}(P)$  is given by  $P = \text{conv}(V)$  then

$$P^\Delta = \{a : aV \leq 1\}$$

7. if a polytope  $P$  with  $0 \in \text{int}(P)$  is given by  $P = P(A, 1)$  then

$$P^\Delta = \{cA : a \geq 0, c1 = 1\}$$

## 9 Simplicial and Simple Polytopes

**Proposition 4.** For any  $d$  dimensional polytope  $P$ , the following are equivalent

1. every facet of  $P$  is a simplex i.e.  $P$  is simplicial

2. every proper face of  $P$  is a simplex

3. every facet has  $d$  vertices

4. every  $k$  face has  $k + 1$  vertices, for  $k \leq d - 1$

Similarly the following are equivalent

1. every vertex figure of  $P$  is a simplex i.e.  $P$  is simple
2. every iterated vertex figure of  $P$  is a simplex
3. every vertex is in  $d$  facets.
4. every  $k$  face is contained in  $d - k$  facets for  $k \geq 0$

## 10 Linear Programming

**Lemma 4.** Let  $v \in \text{vert}(P)$  be a vertex and  $N(v)$  be the set of its neighbors in  $G(P)$ . Then the cone (based at  $v$ ) spanned by the neighbors of  $v$  contains  $P$ .

$$P \subseteq v + \text{cone}\{u - v : u \in N(v)\}$$

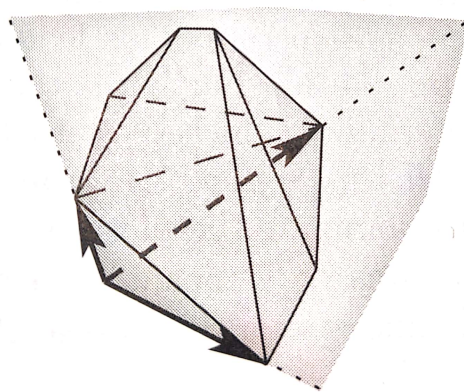

Figure 8: Cone by neighbors of  $v$

**Theorem 6.** If  $cx$  is a linear function in general position for  $P$  then the orientation of  $G(P)$  induced by  $c$  is acyclic with a unique sink. This sink is the unique point in  $P$  where  $cx$  achieves its maximum.

*Proof.* Along any directed path  $v_0, v_1, \dots, v_k$  in  $G(P)$  the value of  $cx$  increases strictly. Thus a directed path cannot return to its starting vertex and there is no directed cycles. Therefore the induced orientation of  $G(P)$  is acyclic and it has a sink.

Now assume that  $v$  is a sink then all of its neighbor  $w \in N(v)$  satisfy  $cw < cv$ . By lemma this implies that  $cx < cv$  holds for all  $x \in P$  with  $x \neq v$  that is  $v$  maximizes  $cx$  over  $P$  and is the only point in  $P$  that achieves maximum.  $\square$

## 11 The Hirsch Conjecture

The diameter of a graph  $G$  denoted by  $\delta(G)$ : the smallest number  $\delta$  such that any two vertices in  $G$  can be connected by a path with at most  $\delta$  edges.

**Proposition 5.** *For  $n > d \geq 2$  let  $\Delta(d, n)$  denote the largest possible diameter of the graph of a  $d$  polytope with  $n$  facets. Then*

$$\Delta(d, n) \leq n - d$$

The Hirsch conjecture was finally resolved negatively in 2010 by Francisco Santos who discovered a 43 dimensional polytope with 86 facets with diameter greater than 43.

## 12 Kalai's method

**Theorem 7.** *If  $P$  is a simple polytope then the graph  $G(P)$  determines the entire combinatorial structure of  $P$ .*

*In other words if two simple polytopes have isomorphic graphs, then their face lattices are isomorphic as well.*

## 13 References

- Lectures on Polytopes , Gunter M. Ziegler
- Handbook of discrete and computational geometry , Goodman , Rourke , Toth
- Introduction to piecewise-linear topology , Colin Patrick Rourke, Brian Joseph Sanderson
- Lecture notes from <https://riliu.math.ncsu.edu/724/notesse3.html>